

Online Fixed Gas Detector GD300:XX Instruction Manual



Notice to Reader

Please read this instruction manual before using the detector

1 Read before operation

1) All operators who operate and test the instruments must read the instruction manual carefully before operation. The instruments can only work properly when they are operated in accordance with the company's instructions for use.

2) The use of the instruments must be operated in accordance with the procedures determined in the manual.

3) The maintenance of the instrument and the replacement of parts are handled by our company or local maintenance stations.

4. If the user does not follow the above instructions to repair or replace parts without authorization, the operator is responsible for the reliability of the instrument, and our company is no longer responsible for the warranty.

5) The instrument should be calibrated at least once a year (it is recommended to calibrate every 3-6 months); the explosion-proof disc of the sensor should be cleaned regularly (purging with low-pressure compressed air) according to the applicable scene, otherwise dust and impurities will block the protective hole, which will affect the detection sensitivity.

6) The use of the instruments should also comply with the laws and regulations of relevant domestic departments and the management of instruments in the factory.

Warranty

The instruments produced by our company have a 12-month warranty period and lifetime maintenance. The warranty period starts from the date of delivery. During use, the user should follow the instructions. The damage to the instrument due to improper use by the user or poor working environment is not covered by the warranty. The user should keep the factory certificate properly, and the warranty period is subject to the date on the certificate. Please pay attention to attach the factory certificate when returning for repair.

Contents

1 Read before operation	-----	3
2 Structure diagram	-----	5
3 Installation method	-----	5
4 Wiring Instructions	-----	8
5 Calibration method	-----	11
6 Remote controller operation	-----	14
7 Common faults and repairs	-----	16
8 Instrument configuration	-----	16
9 Appendix	-----	17

2 Structure diagram

- 1, Power supply and Signal line entrance and exit
- 2, Circuit board
- 3, Terminals
- 4, Sound and light alarm interface
- 5, Sensor head
- 6, Sensor head interface
- 7, Connect the claw socket to the mainboard

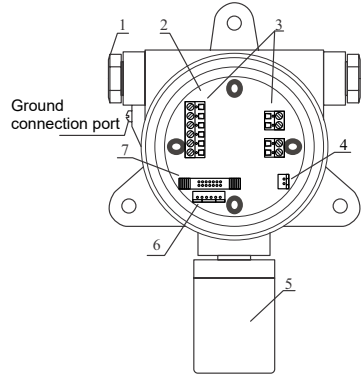

3 Installation method

Select the installation location

The installation position is very important to achieve the best detection effect.

When determining the location, it is necessary to comprehensively consider the following factors:

such as the density of the gas leak point, the specific gravity of the gas to be measured, the influence of the surrounding buildings, the age of the production equipment, the wind direction and the weather conditions all year round, etc. The location of doors and windows should also be considered indoors.

The following suggestions are for users' reference:

A. Appropriate distance should be maintained between the instrument and the possible leakage point of the gas to be tested. If it is too close, the reaction speed will be very fast, but if the leakage is frequent, it will cause too many alarms, or the long-term alarm state will make people paralyzed; if it is too far, the reaction speed will be too slow, or even no response.

B. The instrument should be installed in the downwind direction of the leakage point.

C. When installing indoors, if the leakage source is outdoors, the instrument should be installed at the air inlet.

D. The installation height should be determined according to the specific gravity of the measured gas and air.

E. The number of instruments should be selected according to the possible leakage points of the gas to be measured, the frequency of personnel appearance and the residence time, so as to achieve the best detection effect.

F. If the equipment is outdated, it can be considered to increase the measured points.

G. The instrument should be prevented from being radiated by a high temperature heat source. Too high or too low temperature will affect the use effect and lifetime of the sensors.

H. The instrument should be protected from damp and rainwater inflow, which will affect the internal circuit board.

The wiring recommendations are shown in the diagram below.

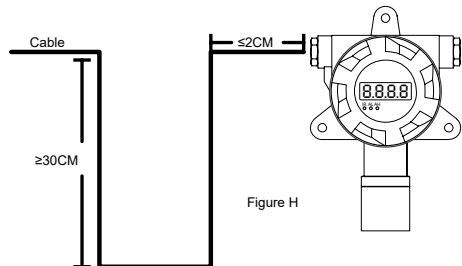

Figure H

Select the installation type

1) Wall-mounted type: This type of installation is usually selected for normal indoor inspection.

According to the size of the outer hole of the mounting bracket (optional), fix two or four 6mm expansion bolts on the wall, and fix the bracket and the detector with screws, nuts, spring washers and flat washers.

Then use 6x30mm nuts and spring washers to fix the expansion bolts on the wall, see the picture below.

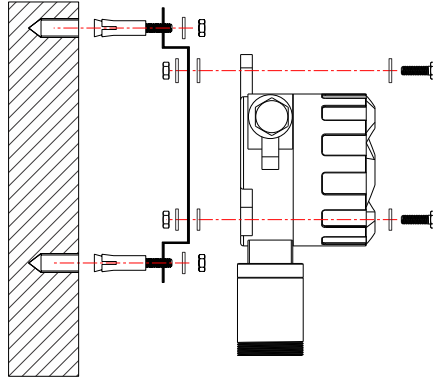

Note: The installation location must be well grounded or insulated. Leakage of electricity may cause the detector to work abnormally.

2) Pipe-mounted type: The installation thread size of the instrument is M45*P2.0. During the installation process, hold the detector with both hands so that the sensor is parallel to the installation thread, align the screw mouth, rotate the detector clockwise, and then install the detector on the target position. In order to prevent air leakage at the threaded interface, suitable raw tape can be wrapped around the threads on the sensor head before installation.

Note: The pipe-mounted type requires that the inside of the pipeline is normal temperature and pressure (temperature -20~50°C, pressure 0.1mPa) and humidity $\leq 95\%RH$. If the above conditions are not met and this installation method is required, please contact the manufacturer for a solution.

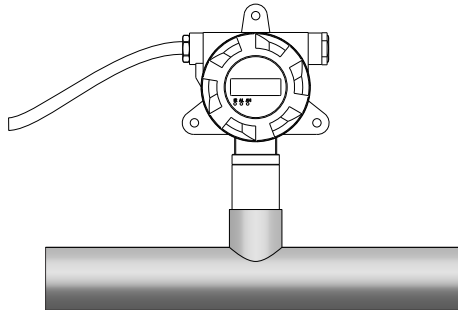

Instrument Dimensions and Mounting Hole Map

- Appearance and installation hole map

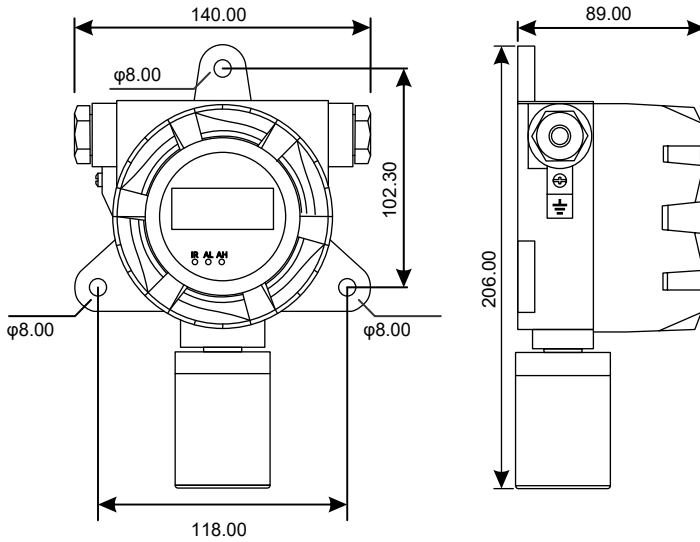

- Appearance and installation hole map of gas detector with alarm light

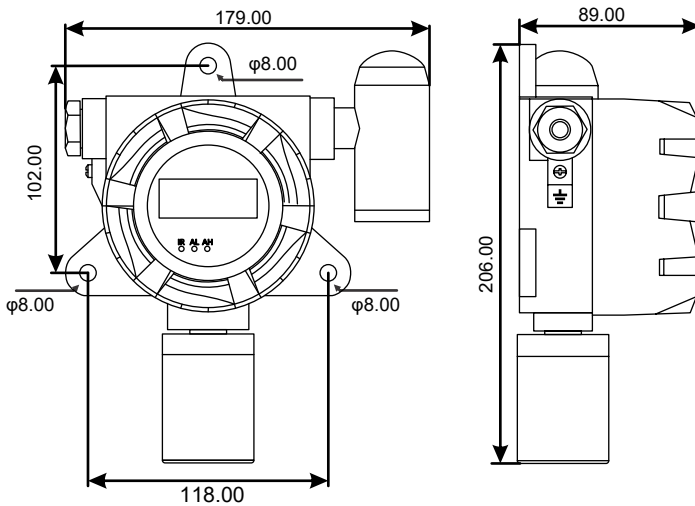

4 Wiring Instructions

4.1, Cable requirements:

Power lines and 4-20mA signal lines need to use shielded cables, and RS485 lines are recommended to use twisted pairs. When using RS485 communication to connect with the controller (Under normal conditions), the RS485 signal transmission distance of our detector can reach more than 1000 meters. When the signal interference is large or the transmission distance is longer, it is recommended to add an RS485 repeater, a 120Ω/0.5W matching resistor should be connected in parallel between the A and B lines of the farthest detector.

The power supply voltage of this series of detectors is 12~24VDC. Due to the voltage drop caused by the impedance of the cable itself, it should be ensured that the minimum supply voltage of all detectors is 12VDC.

When the detector is powered by the controller, the power supply voltage of the controller of our company is 24VDC. To ensure that the minimum input voltage of the detector is 12VDC, the circuit voltage drop must be less than or equal to 12VDC, as shown in the figure below.

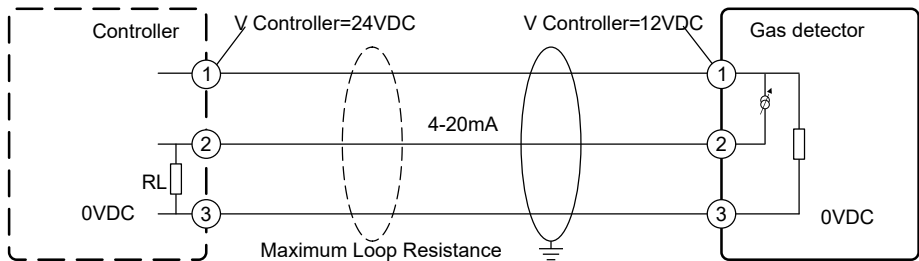

Maximum Loop Impedance: $R_{loop} = (V_{Controller} - V_{Detector(min)}) / I_{Detector}$ Calculated according to the above formula.

The maximum current of combustible gas detector is 250mA, and the maximum loop resistance is 48Ω;

The maximum current of the toxic gas detector is 100mA, and the maximum loop resistance is 120Ω.

The cable cross-sectional area and the farthest transmission distance are shown in the table below (when connected to our controller). Make sure that the actual installed cable length is shorter than the calculated maximum cable transmission distance.

Cross-sectional area of cable core (mm ²)		0.75	1.00	1.50	2.50
Resistance (ohm/km copper wire)		24.7	18.5	12.3	7.4
The longest cable distance (m) (loop length/2)	Combustible gas	1000	1250	2000	3200
	Toxic gas	2400	3200	5000	8000

Note: The above transmission distance is calculated based on the cable core with a resistivity of $1.85 \times 10^{-2} \Omega \cdot \text{mm}^2$. If a cable of the same wire diameter with a smaller resistivity than this is used, the transmission distance can be longer; if a cable of the same wire diameter with a higher resistivity than this is used, the transmission distance will be shortened. The loop length indicates the total length of the positive and negative wires of the power supply, and the actual length of the cable is equal to half of the loop length.

Refer to the following formula for the maximum number of detectors allowed on a single cable: $N=Im/Ic$
 $Ic=((U-12)/R)/lc=((U-12)/(\rho \cdot L/S))/lc$

N: Maximum number of detectors

Im: the maximum current passing through the wire(A)

Ic: the average current of a single detector at the lowest starting voltage(A)

U: controller output voltage (our controller is 24V)

R: internal resistance on the cable(Ω)

ρ : core resistivity (copper: $1.85 \times 10^{-2} \Omega \cdot \text{mm}^2$)

L: cable length (the total length of the positive and negative lines of the power supply, if the length

of a single line is 100m, the total length of the two lines is 200m)

S: core cross-sectional area(mm^2)

When the detector uses our controller to supply power, taking the material as copper (the resistivity is $1.85 \times 10^{-2} \Omega \cdot \text{mm}^2$) as an example, the maximum number of detectors allowed for a single cable can refer to the following table:

When the detector is not powered by the controller (that is, powered by an independent power supply), the 4-20mA transmission distance is determined by the load resistance, which includes the output resistance of the control system (controller, DCS or PLC) and the internal resistance of the cable.

Cable distance (m)		100	200	500	1000
The maximum allowable number of detectors when using 0.75mm ² wire diameter	Toxic gas(100mA@12V)	24	12	4	2
	Combustible gas(250mA@12V)	10	5	2	1
The maximum allowable number of detectors when using 1.0mm ² wire diameter	Toxic gas (100mA@12V)	32	16	6	3
	Combustible gas (250mA@12V)	12	6	2	1
The maximum allowable number of detectors when using 1.5mm ² wire diameter	Toxic gas (100mA@12V)	48	24	8	4
	Combustible gas (250mA@12V)	20	10	4	2
The maximum allowable number of detectors when using 2.5mm ² wire diameter	Toxic gas (100mA@12V)	80	40	15	7
	Combustible gas (250mA@12V)	30	15	6	3

The maximum transmission distance refers to the following formula:

$$L=(R-Rc)/(\rho/S)$$

L: Maximum transmission distance(m)

R: Maximum load resistance(Ω) (500 Ω when powered by 24V, including control system input resistance and cable internal resistance)

Rc: input resistance of the control system (the input resistance of our controller is 50 Ω) ρ :

core resistivity (copper: $1.85 \times 10^{-2} \Omega \cdot \text{mm}^2$)

S: core cross-sectional area(mm^2)

4.2 Wiring Instructions

1: Cable requirements: use shielded cables, the wire diameter is about 0.75mm, and the copper wires at the wiring must be tightened without burrs;

2: Different instruments, the wiring methods are different:

A. For instruments with lead wires, the following are the meanings of each connection wire (for reference only):

Red wire: Power positive input (12 to 24V)

Black wire: power ground wire

Yellow wire: 4~20mA output or RS485A

Green wire: RS485B

B. For instruments without lead wires, the user needs to open the instrument shell and connect wires to the inside terminals. The following figure is the description of each terminal:

Warning: The wiring work must be performed by professionals, otherwise it may cause electric shock or damage to the instrument.

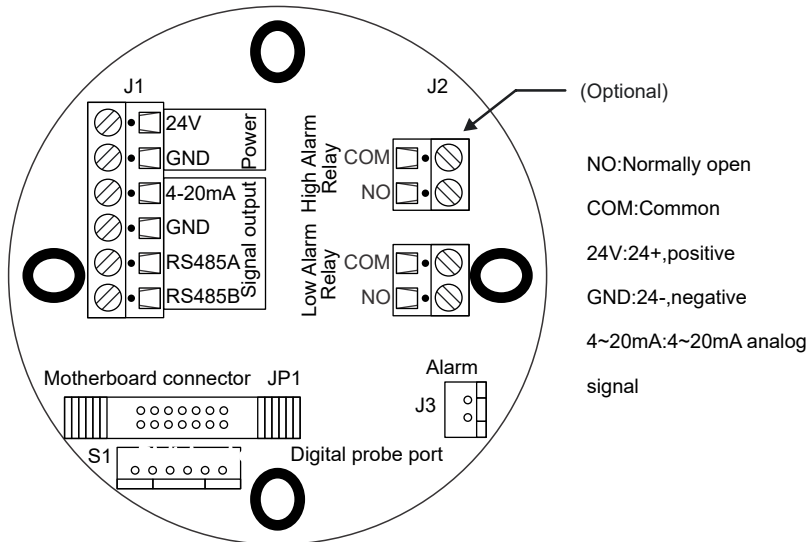

Note: Do not connect wires with power on at any time.

* High alarm relay (Optional) .

Wiring diagram

External load application (low alarm for reference)

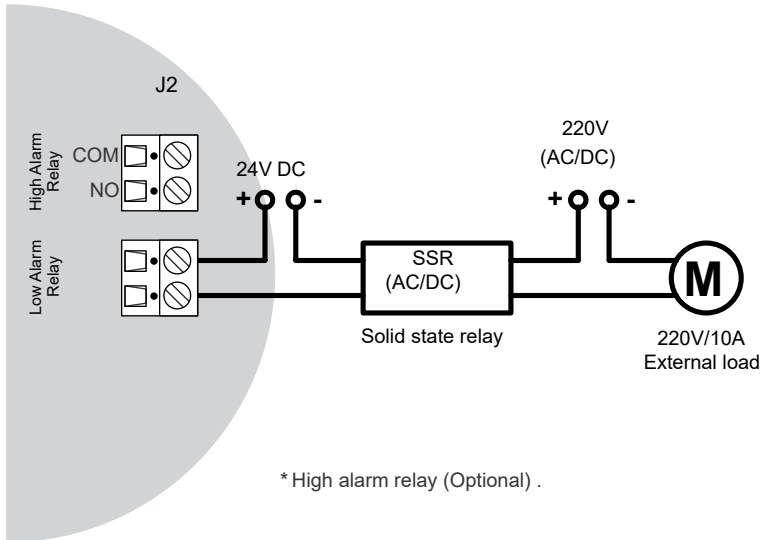

5 Calibration method

In order to ensure the measurement accuracy, the instrument should be calibrated regularly and strictly recorded during use.

Calibration equipments:

One bottle of calibration gas with known concentration (Note: The instrument defaults to full scale. In principle, the selected calibration gas concentration should be greater than 50% of the range and less than the range.);

- Pressure reducing valve;
- flow meter 0~1000ml/min;
- PTFE tube;
- Calibration cap, etc.

Note: When the instrument leaves the factory, the alarm settings of the detector and the panel are adjusted to the factory default values, and the user can adjust it through the remote controller according to the situation.

Zero calibration

Make sure the instrument is in clean air environment (do not do this in a non-clean air environment).

Note: After the zero point calibration, the instrument reading will automatically return to zero (oxygen 20.93% VOL, nitrogen 78.1% VOL, carbon dioxide 450ppm).

Power on when ready.

The zero calibration steps are as follows:

1: Press the "MENU" key on the remote controller, then instrument displays F-01.



IR ALAH
○ ○ ○

2: Press "+" key or "-" key to adjust to F-04.



IR ALAH
○ ○ ○

3: Press the "OK" key to display the current gas concentration reading. Wait until the instrument value is stabilize, press the "OK" key again, then detector reading will display "PASS", indicating that the calibration is successful.



IR ALAH
○ ● ●

4: If the zero calibration is successful, it will automatically return to the detection interface.



IR ALAH
○ ○ ○

Span calibration

Connect the calibration gas cylinder of known concentration to the calibration cap (Optional) of the instrument(as shown in the figure below) through PTFE pipe.

This operation is mainly divided into two steps: [Set Calibration Point] and [Span Calibration].

Note: After the calibration, please remove the calibration cap. Do not install the calibration cap on the detector during testing.

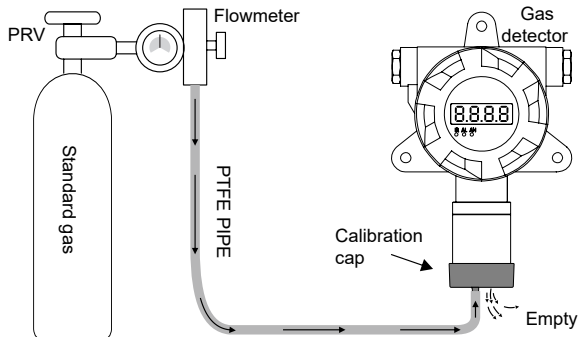

• Set the calibration point

Make sure the detector is connected correctly, power on until the output of the detector is stable.

1. Press the "MENU" key on the remote controller, the detector displays F-01.



IR ALAH
○ ○ ○

2. Press the "+" key or the "-" key to adjust to F-07.



IR ALAH
○ ○ ○

3. Press the "OK" key to enter the gas concentration value display interface. The value can be modified by the "+" and "-" keys to make the value consistent with the calibration gas concentration. Press the "OK" key to display "PASS" briefly.



IR ALAH
○ ○ ○



IR ALAH
○ ● ○

• Span calibration

1. Press the "BACK" key to exit, the detector will display F-07.



IR ALAH
○ ○ ○

2. Press the "+" key to display F-08,



IR ALAH
○ ○ ○

3. Press the "OK" key again to enter the function interface. After adjusting the "0" displayed on the interface to "1" by the "+" key, press the "OK" key again to display the current detection reading.



IR ALAH
○ ○ ○



IR ALAH
○ ○ ○

4. At this time, pass in the calibration gas at 300 ± 20 ml/min. When the value of the instrument is stable, press the "OK" key. The instrument will be automatically calibrated and display "PASS" for a short time. At this time, the measured concentration value is consistent with the value set in "F-07" (concentration value of calibration gas).



IR ALAH
○ ● ●

Note: Pass the calibration gas into the detector. After the output is stable, adjust and correct the display value of the detector to be the same as the calibration gas value, and then cut off the gas. Observe whether it can return to the zero point (in a pure air environment) or the starting point, and then repeat it again, and the calibration can be completed with a small difference between the two values (within the basic error range). If there is a big difference, repeat the above method to calibrate until the calibration specification is met (the detector is usually adjusted to "20.93% VOL" for oxygen in the air environment, and the detector is usually adjusted to "78.10% VOL" for nitrogen in the air environment).



IR ALAH
○ ○ ○

6 Remote controller operation

Remote controller key function



Key	Function
MENU	Enter the parameter setting state from the detection state
RESET	Cancel the alarm state
+	Displayed parameter increase 1
-	Displayed parameter minus 1
OK	Confirm the operation
BACK	Cancel operation/return

1: Press the MENU key once to enter the F-01 address code setting menu, press the "OK" key to enter the modification, press the "+" and "-" keys to modify the instrument address code, and press the "OK" key to save after the modification is completed. Press the "BACK" key to cancel.

2: Press the "+" key to enter F-02 to enter the low alarm point setting menu, and press the "OK" key to enter the modification. Press the "+" or "-" key to modify the low alarm value of the instrument. After the modification is completed, press the "OK" key to save, and press the "BACK" key to cancel.

3: Continue to press the "+" key to enter F-03 to enter the high alarm point setting menu, and press the "OK" key to enter the modification. Press the "+" and "-" keys to modify the high alarm value of the instrument. After the modification is completed, press the "OK" key to save, and press the "BACK" key to cancel.

4: In the parameter setting state, if the remote controller is not operated for 10 seconds, the instrument will automatically return to the gas detection state, and the parameters being modified (without pressing the "OK" key to confirm the operation) will not be saved in the EEPROM. The parameters used are still the previous values when restarted again.

F-0X function table

F-01	address settings	RS485 communication address modification
F-02	low alarm value setting	The setting value cannot exceed the high alarm value
F-03	High alarm value setting	The setting value cannot be lower than the low alarm value
F-04	Zero calibration	Calibration after stable reading in clean environment
F-05	4mA current trimming	C-04, 4mA output (modifiable) C-08, 8mA output (cannot be modified) C-12, 12mA output (cannot be modified) C-16, 16mA output (cannot be modified) C-20, 20mA output (modifiable)
F-06	ADC value	Cannot be modified
F-07	Set calibration point	Span calibration concentration value
F-08	Span calibration	Change 0 to 1, press the OK key, the real-time concentration value will be displayed, and then press the OK key to calibrate as the value set in F-07
F-09	Production date	cannot be modified
F-10	Communication protocol	0:Standard version 1:Non-standard version (old protocol)

Note: F-06 and below operations do not need to be operated under normal circumstances, and only professionals can operate when necessary. F-11 to F-19 are reserved functions, please consult the manufacturer for details.

7 Common faults and repairs

Trouble phenomenon	Reasons	Solution
Detector has no output	Wrong wire connection	Reconnect correctly
	Circuit failure	Send back for repair
Detector reading is low	Calibration expired Detector	recalibrate
	range is set too high Sensor	Reset the detector range
	failure	Replace the sensor
Detector reading is high	Calibration expired Detector	recalibrate
	range is set too low Sensor	Reset the detector range
	failure	Replace the sensor
Detector reading is not stable	Not enough warm-up time	Power on and waiting
	Sensor failure	Replace the sensor
	Circuit failure	Send back for repair
Display“----”	The detector signal wire is disconnected	Plug the signal wire tightly

8 Instrument configuration

- 1, Gas detector 1 piece
- 2, Instruction Manual 1 piece
- 3, Product certificate 1 piece
- 4, Remote controller 1 piece
- 5, Label 1 piece 1 piece
- 6, packing box 1 piece

9 Appendix

Connection diagram of multiple instruments

According to the signal type of the user's implementation site, 4-20mA current signal output and RS485 digital signal output can be selected respectively

These two signal output modes are also different when wiring

A. 4-20mA current signal output connection mode. (must be grounded together)

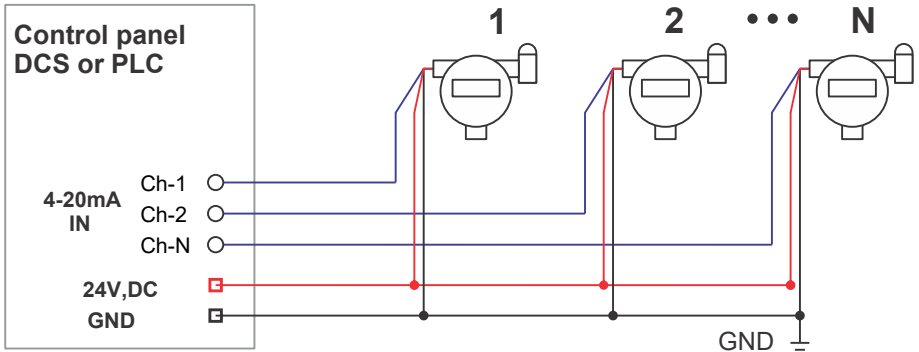

B. RS485 digital signal output connection mode 1. (can be independently grounded)

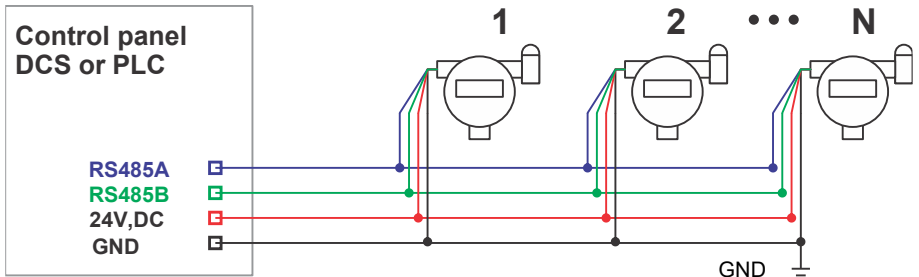

C. RS485 digital signal output connection mode 2. (can be independently grounded)

